

# TC6-FS type TOYOCONNECTOR® Handling Manual ( TOYOX silicone hose connector )

Be sure to read this manual before using the connector.

**Warning:** A potentially hazardous situation which could result in death or serious injury.

This is an instruction for the correct use of TOYOCONNECTOR. Like the hoses itself, there are also limitations for the use of TOYOCONNECTOR. Please observe the following safety precautions fully. Failure to observe these could result in injury or property damage.

## Names of parts ( materials )

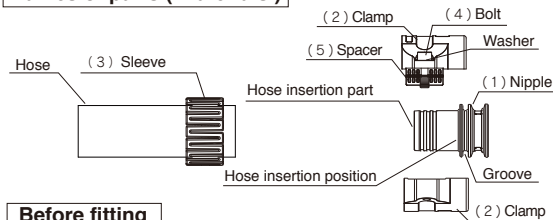

## Materials

- ( 1 ) Nipple : SCS16 ( SUS316L equivalent )
- ( 2 ) Clamp : SCS14 ( SUS316 equivalent )
- ( 3 ) Sleeve : PVDF
- ( 4 ) Bolt : SUSXM7 ( SUS304 equivalent )
- ( 5 ) Spacer : PVDF
- Washer ( TC6-FS50 only ) : PEEK
- Lubricant of the bolt screw portion : NSF " H1 " registered grease

## Before fitting

**Note** This connector should not be disassembled for cleaning on a daily basis.

**Warning** When replacing a hose or disassembling a connector, wait until the connector is cooled down to the room temperature. If not, you may get burned or the connector may get damaged.

- When cutting a hose, please make sure that the edge face of the hose will become square-on.
- If there are any loose strings or hard wires coming out from the end of the hose, be sure to remove such with nippers, etc. Take care such that the hose scraps, loose strings, or hard wires do not enter the hose.
- Be sure to have a sufficient hose length so as not to apply a hose bending stress around a connector.
- Make sure that the hose is inserted completely into the root of the hose insertion part of nipples.
- Warning** When inserting hoses into TOYOCONNECTOR, never put grease on the surface of the hose insertion part of nipples. It would be a cause of hose being pulled out.
- Fasten the clamp after confirming the direction of each component.
- Be careful of injuries caused by tools slipping during the fastening process.
- Be sure to use a " hex wrench " that is at least 180mm long to fasten the bolts ( at least 200mm long for TC6-FS50 ). Fasten the 2 bolts evenly while alternating and fasten these until there are no gaps. When used in a state where there are gaps, trouble due to leaked fluids and detached hoses will occur. Refrain from using an impact driver when fastening the bolts. Doing so may damage the screws of the clamp.
- Note** Complete fastening cannot be achieved with uneven fastening.
- Note** A lubricant ( Extreme pressure grease ) registered with NSF " H1 " is approved for use in areas that may accidentally come into contact with food " is applied to the screw portion of the clamp of TC6-FS.
- Note** When fastening the unit, there rarely may be cases when resin or metal dust ( or stringy shavings ) is generated. Be sure to remove such prior to use.

## How to attach a hose

\* The same mounting instruction applies to all hoses.

- Loosen the ( 4 ) bolt and remove the ( 2 ) clamp from the ( 1 ) nipple.
- To adjust the hose length, fix the ( 1 ) nipple to the target piping. Next, cut the hose end vertically while adjusting it to make sure that it is not put under tension.
- Remove the ( 1 ) nipple from the pipe and perform the assembly. Place the ( 3 ) sleeve over the hose. By marking a line in advance on the hose according to the " Appropriate Sleeve Insertion Volume " table on the right, it will be possible to appropriately align the position of the sleeve.
  - \* The sleeve has lateral symmetry, with no insertion directionality.
  - \* If the sleeve combination part is misaligned, realign it and adjust so that there is no bump.

TOYOCONNECTOR Code	Size of hexagonal bolt hole
TC6-FS32	6mm
TC6-FS38	6mm
TC6-FS50	8mm

TOYOCONNECTOR Code	mm
TC6-FS32	45
TC6-FS38	50
TC6-FS50	60

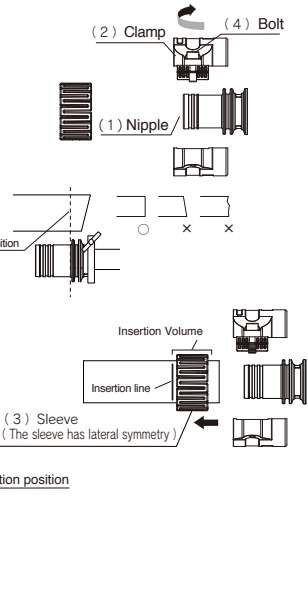

- Provisionally assemble the ( 2 ) clamp in line with the grooves on the ( 1 ) nipple, in the center of the gap. ( Figure 1 )  
\* If the spacer has fallen off of the ( 4 ) bolt, provisionally assemble the ( 2 ) clamp after attaching the ( 5 ) spacer onto the ( 4 ) bolt. ( Figure 2 )
- Fasten the 2 ( 4 ) bolts evenly while alternating and fasten these until there are no gaps. If there is any gap between the clamp components and you cannot fasten the clamp fully, leave the unit for a while and tighten the clamp again until there is no gap left.

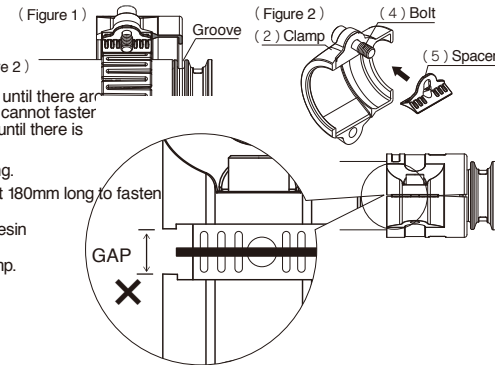

**Note** Complete fastening cannot be achieved with uneven fastening.

**Note** Be sure to use a " hex wrench " that is at least 180mm long to fasten the bolts ( at least 200mm long for TC6-FS50 ).

**Note** When fastening the unit, there rarely may be cases when resin or metal dust ( or stringy shavings ) is generated.

- Fasten the hose to the pipe using a commercially available sanitary clamp. Mount the hose onto the pipe, making sure that the hose is not twisted.
- Note** Clean the inside of the pipe without a failure ( every time after a pipe is connected. )

## Notes for use

- This product is a hose connector dedicated for TOYOX hoses. TOYOX is not liable for any damages caused by using TOYOCONNECTOR with any other hose including those produced by TOYOX as well as those by other manufacturers as full performance may not be achieved or maintained. \* Hose compatibility depends on the connector. Confirm through the catalog or the homepage.
- Maximum operating temperature for the connectors is 140°C. Please read the instruction manual "warning when using hose" (maximum operating temperature) for the compatible hose, and do not exceed the maximum operating temperature of 140°C, please use within nor the maximum pressures range of for the compatible hose.
- Hoses usable under negative pressures may not be applicable depending on applications and conditions ( temperature, movement, etc. ).
- Do not use a hose that is extremely bent near a connector. The bend radius of a hose should be larger than its minimum bend radius.
- Warning** Do not assemble or disassemble the connector while fluid is in the hose because the hose may become loose and the liquid will leak.
- Do not use the hose where there is vibration or shock. It may cause the connector to break or the hose to become detached.
- Perform a start-up inspection and routine inspections thereafter to ensure that the hose has not come away from the connector, no fluid is leaking, and the bolt is tight while in use.
- Do not allow anything other than the inner surface of the couplings or hose to come in contact with fluids, because the fluids may permeate the hose reinforcement layer or remain inside the couplings, and bacteria may propagate (attach to the parts) or the hose may deteriorate. Also, dust and hose fragments (reinforcement material) to the outer surface may be mixed in.
- Warning** Never use TC6-FS for the below applications. Hoses may rupture or become loose.
  - For piping such as electromagnetic valve piping, which would put impact pressure on the piping
  - Where vibration or impact will be applied to the connector
  - Purposes that exceed the maximum temperature of use
  - Where constant tensile stress may be applied to the hoses
  - In a way that may cause static buildup ( There is a danger of electrical shocks. )
- Before using TC6-FS make certain to sterilize and disinfect inside the hoses. ( The hoses do not go through sterilization procedures before shipping. )
- When cleaning TC6-FS, do not rub their surfaces with a hard brush or other things because doing so may damage the surfaces, and bacteria may propagate ( attach to the parts ). Be sure to remove such prior to use.
- Please store the hose at low temperature and humidity. Ensure the connector is sealed for protection against dust and foreign matter.
- Products should be disposed of in accordance with the requirements of the local region.

## Notes for Connector Reuse and Hose Replacement

- When reusing this product, make sure that each of its components is not damaged prior to use. Be sure to replace the sleeve. Please be sure to fasten the bolts after applying a commercially available lubricant ( Extreme pressure grease ) to the screw portions of the bolts and the clamp. Use of a lubricant ( Extreme pressure grease ) registered with NSF " H1 " is approved for use in areas that may accidentally come into contact with food " is recommended.
- Please make sure to use a brand-new hose.
- Before replacing a hose, always make sure to remove the fluid and dirt on the connector surface. Fluid and dirt remaining on connector may possibly cause fluid leakage and hose loosening.
- Although this may differ depending on conditions of use, replace the unit with components or a new clamp set after it has been removed approximately 5 times.
- Do not hit the coupling with a hammer or some other tools.

## Warning

- The material of fluid path ( interior ) of this product uses SCS 16 ( SUS 316L equivalent ) . Phenomena such as corrosion or fluid leaks may occur depending on the type of fluid. Before use, be sure to check data ( refer to data on chemical resistance on the homepage ) . Please also make similar checks for fluid contact with the outer surface of connector.
- Do not use hoses when they are twisted. Partially twisted hoses are also a danger as they may cause internal structural damage leading to a " Burst ". Follow the examples below to take preventative measures.

Example 1 ) Twisted hose while piping

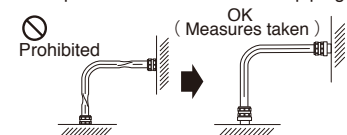

Example 2 ) Twist when bent

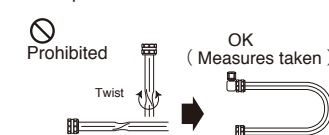

Connect to the Future  
**TOYOX**

**TOYOX CO., LTD.**

<https://www.toyox.co.jp> ISO 14001 certified